



 e-Gizmo.com



 GitHub



 eGizmo
Mechatronics

PBOT JUNIOR: Assembly Manual

An Entry Level Mobile Robot



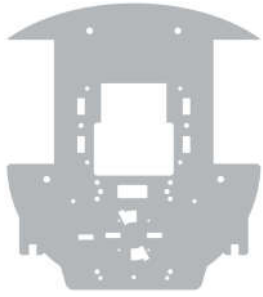

Proudly Made in the Philippines

MATERIALS:

[Body] 

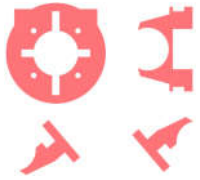
[Front Deck] 

[Roller Holder] 

[Battery holder] 

[Spoiler] 

[Board Chassis] 

[Motor Holder] 

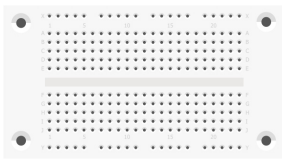
[SYB-46 Breadboard] 

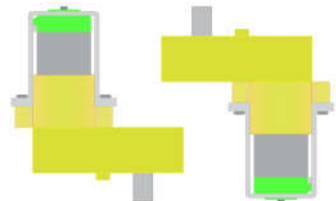
6VDC Motors [2pcs] 

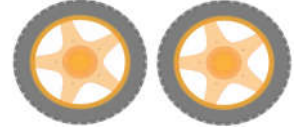
Wheels[2pcs] 

4pins wires 

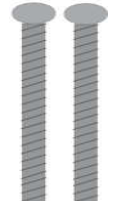
3x20mm[2] 

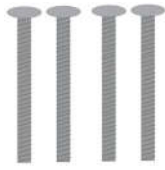
2x25mm [4] 

2.5mm[4] 

3x16mm[4] 

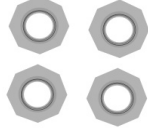
3mm[4] 

Spacers[5] 

3x14mm 

3x10mm[2] 

3x6mm[8] 

1x6mm screws[4] 

Roller Ball 

3x10mm [4] Brass studs 

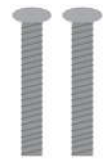
3x12mm[2] 

FIRST STEP: The Roller Holder

1

Chassis:
Acrylic body
Bottom View

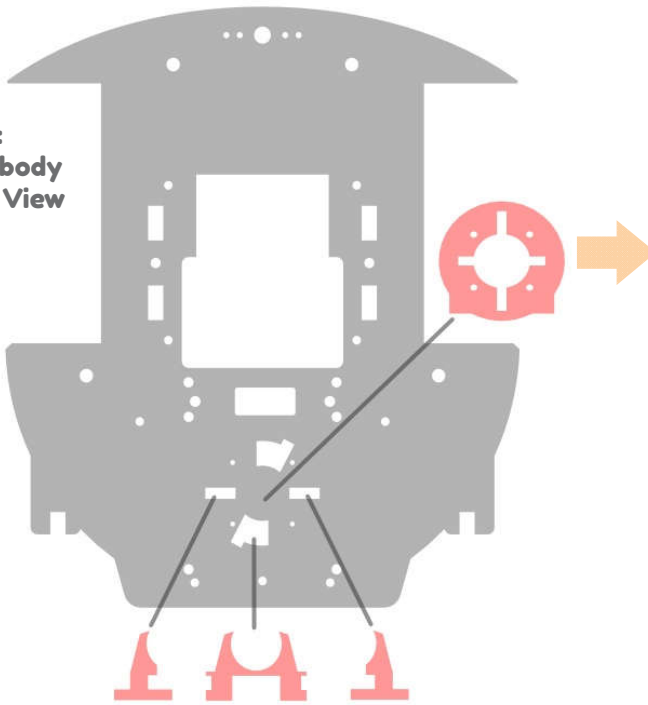

Roller Holder accessories

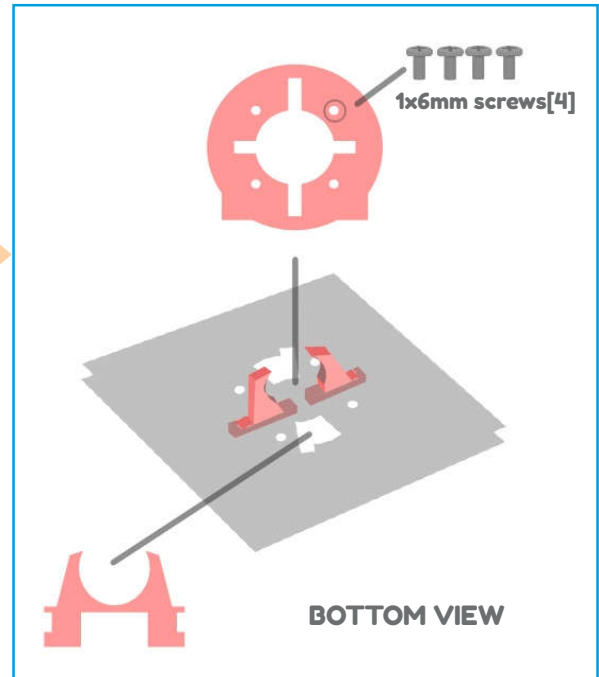

2

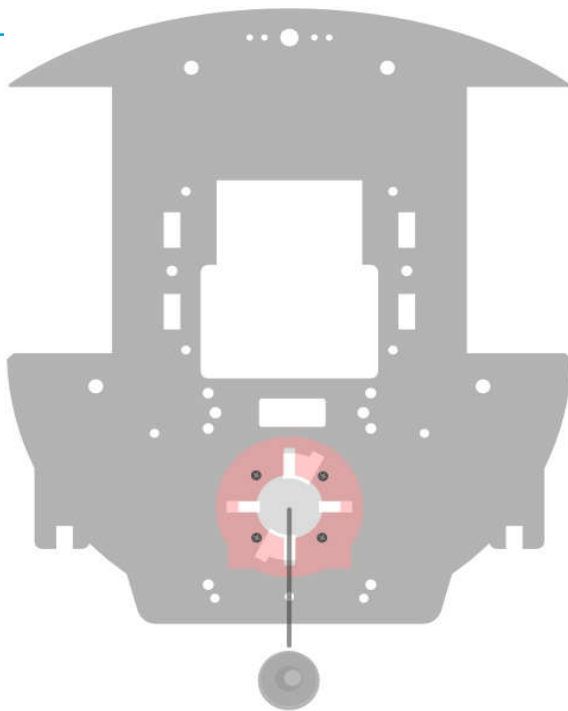

Place the Roller Ball inside of it.

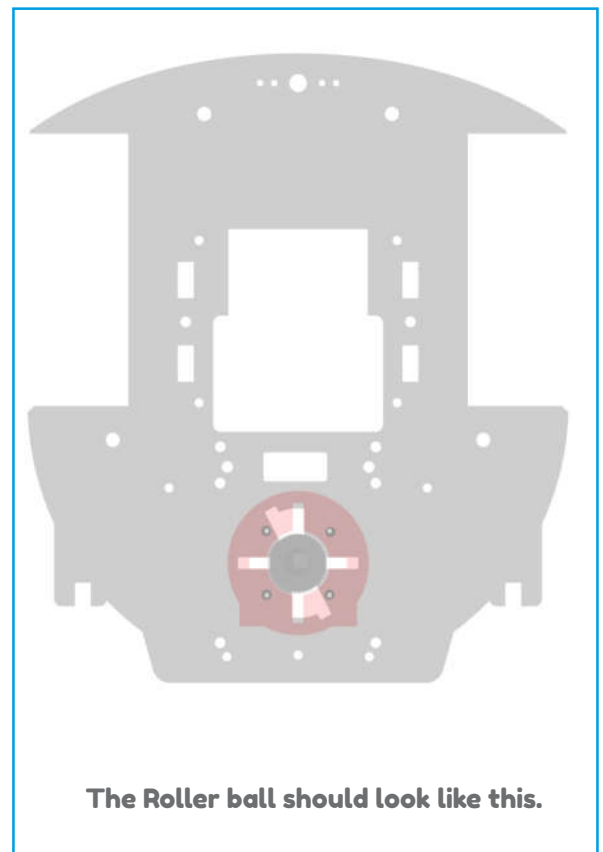

The Roller ball should look like this.

SECOND STEP: Placing the breadboard

1

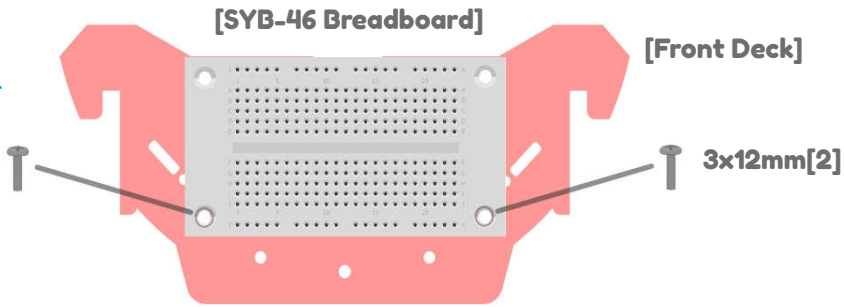

2

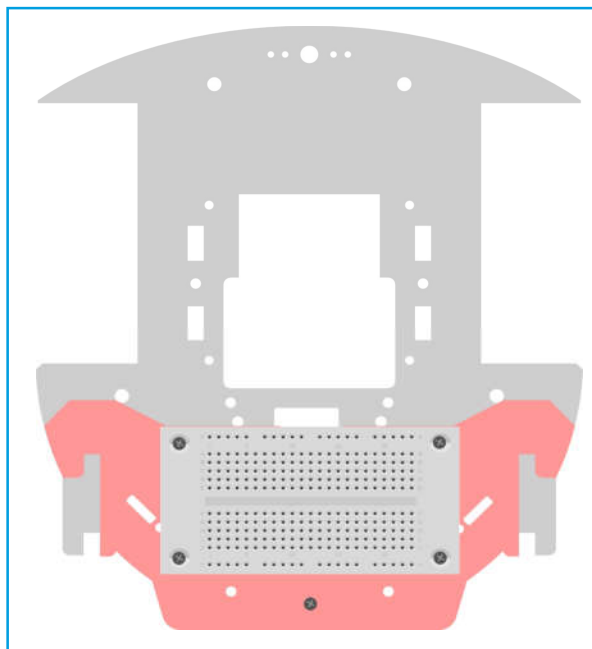
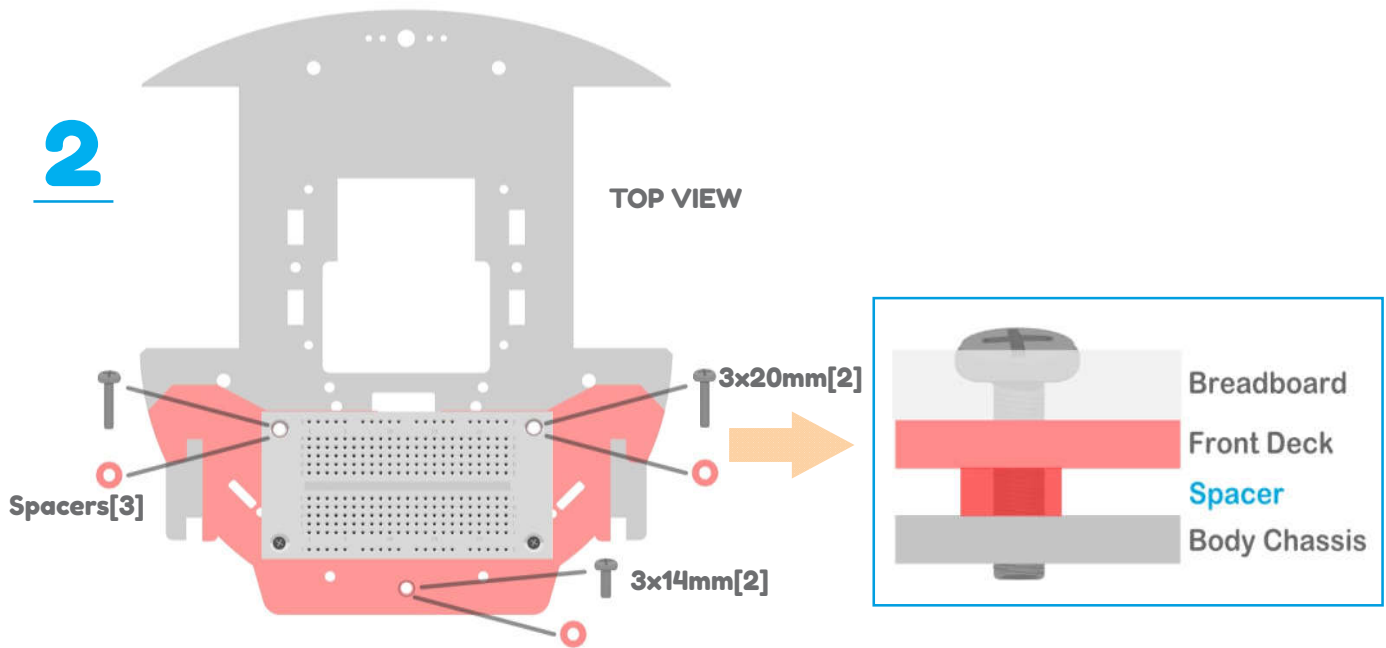

THIRD STEP: Constructing the Motors

1

Screws: 2.5 x 25 mm [2pcs]
Nuts: 2.5 mm [2pcs]

①

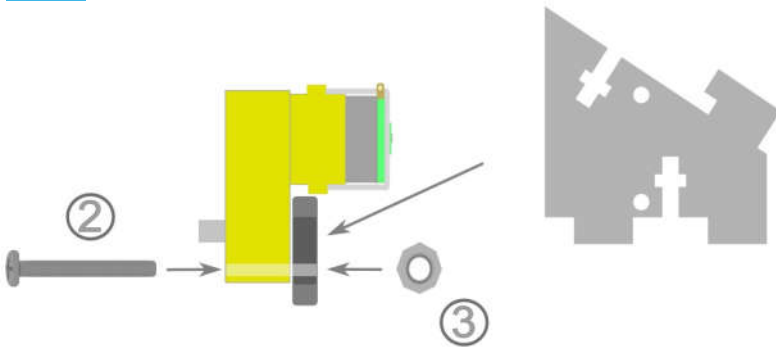

3

Strips the wires

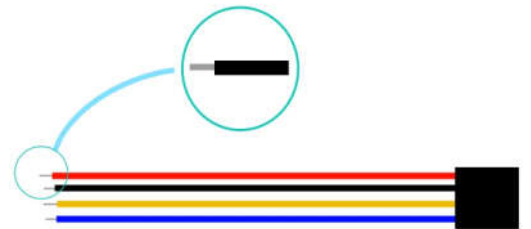

2

Connect the Wheel.

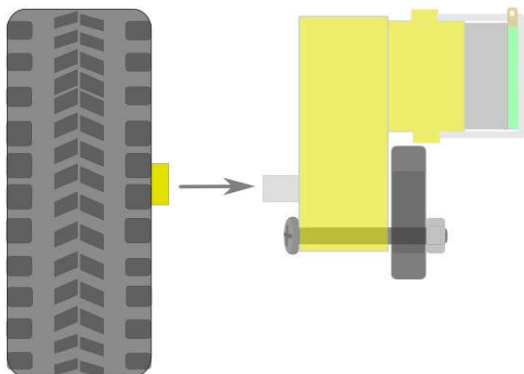

4

Solder the wires to the motor pins

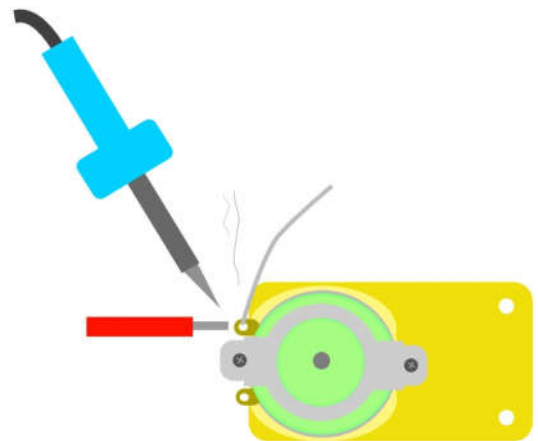

FOURTH STEP: Placing the Motors

Wiring Connections for Motors

Right Motor

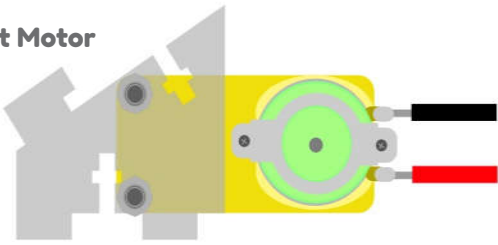

Left Motor

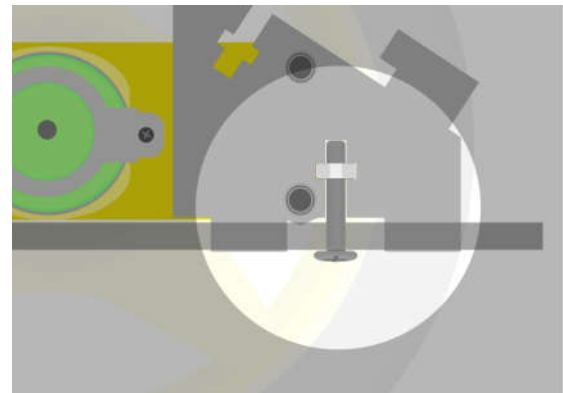
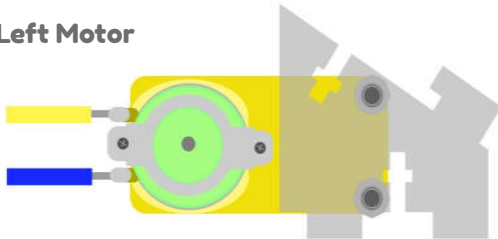

Place the two motor like this.

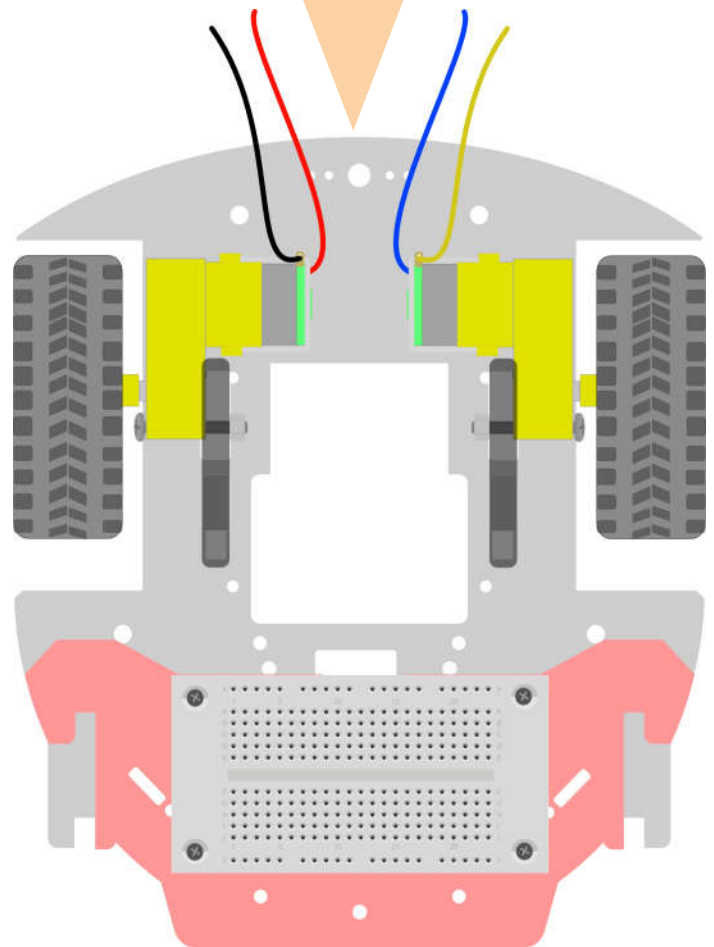

Apply the screws and nuts to support the motor holder.

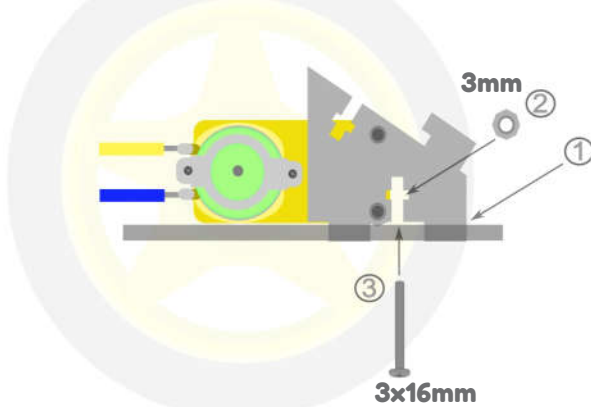

FIFTH STEP: The Board Chassis

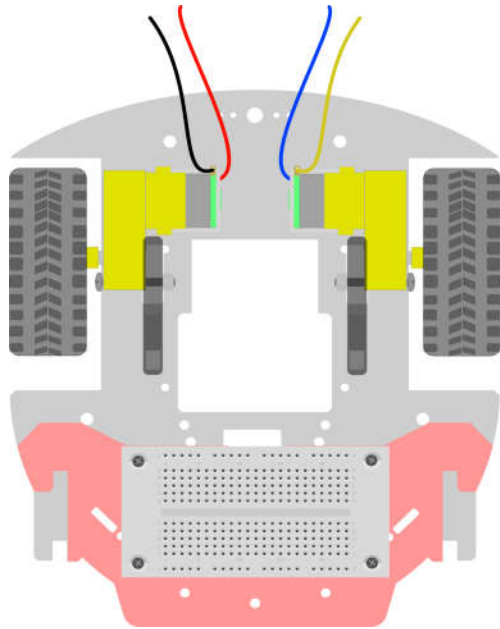
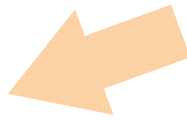
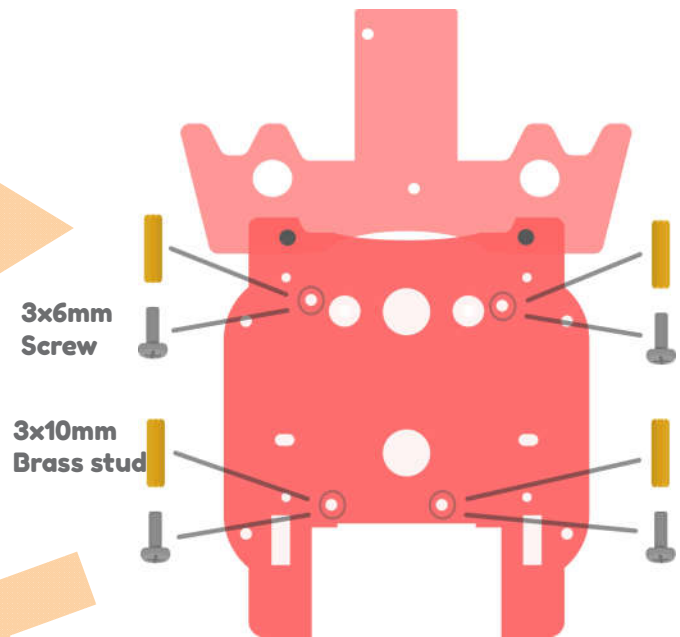
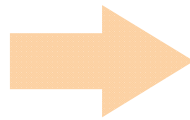
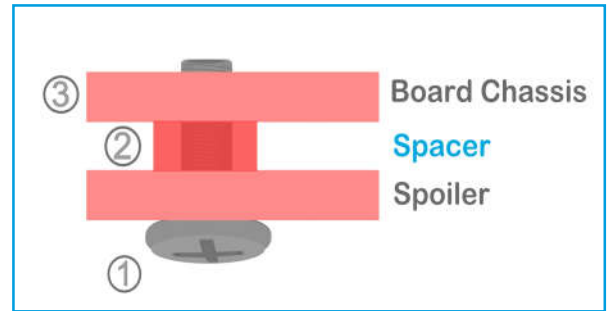
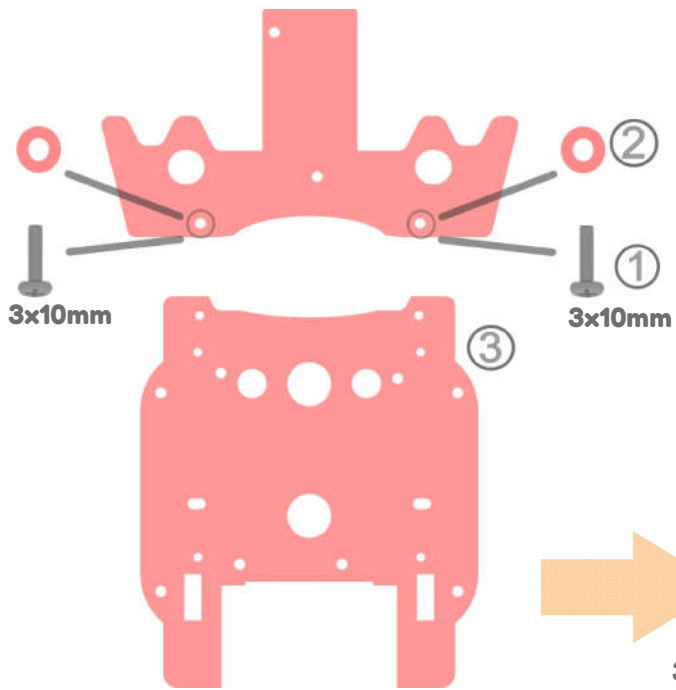

Place it on the top.

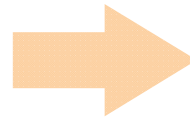

It should be like this.

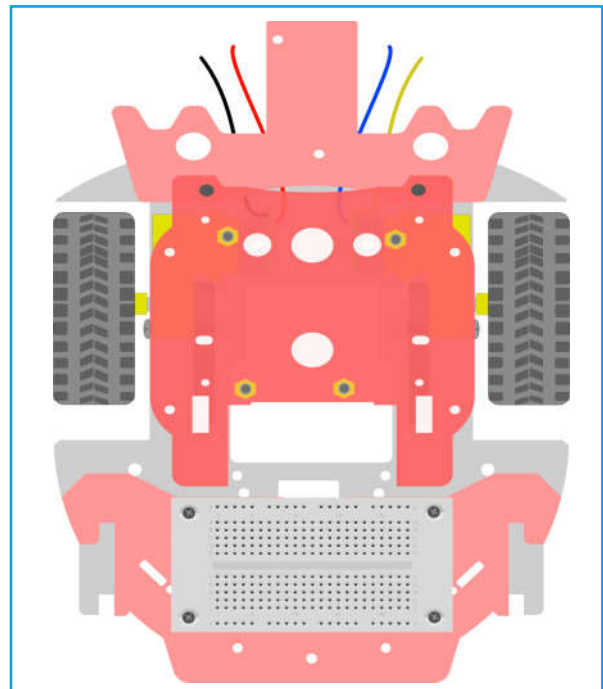

SIXTH STEP: Placing the Upper Board and Battery holder

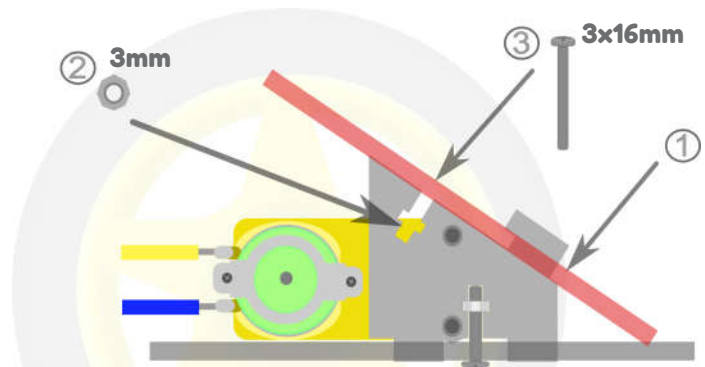
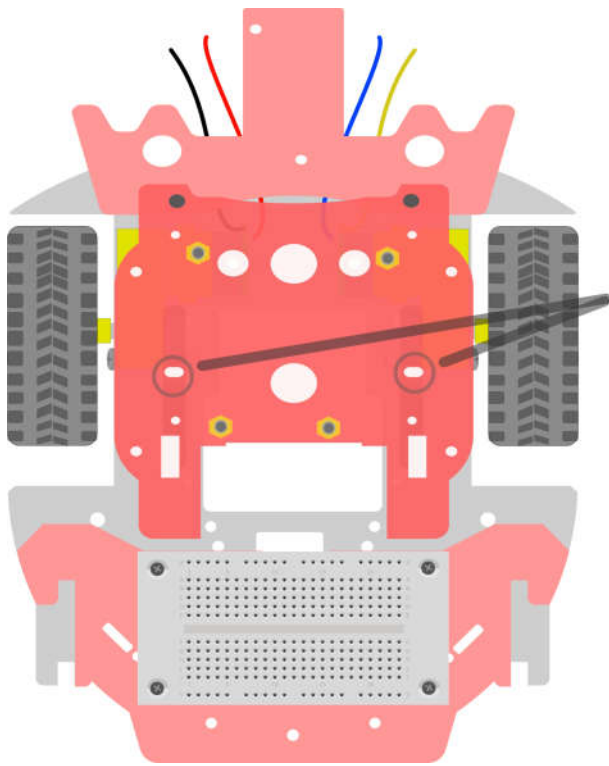

Place the upper board chassis, then add the screws and nuts to tighten it.

Placing the Battery Holder.

